

1800 w

Bohrschablone für Deckenhalter

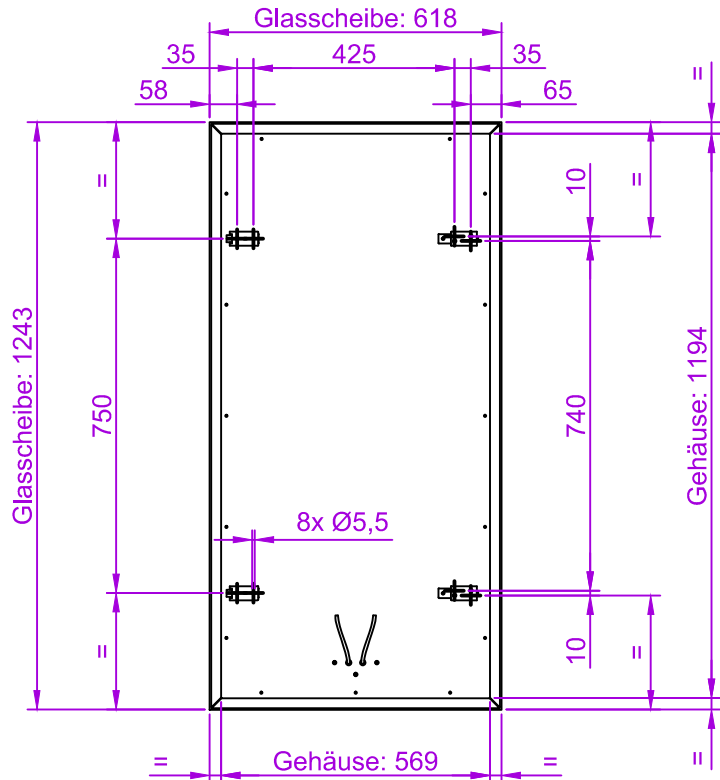

Seitenansicht

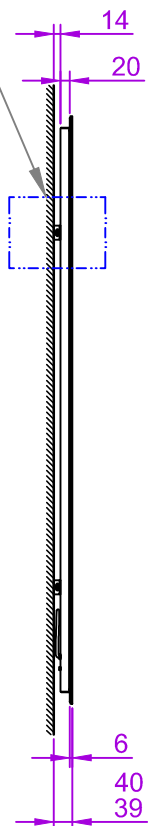

Detail A
VH

Abmessung für Abhängseil

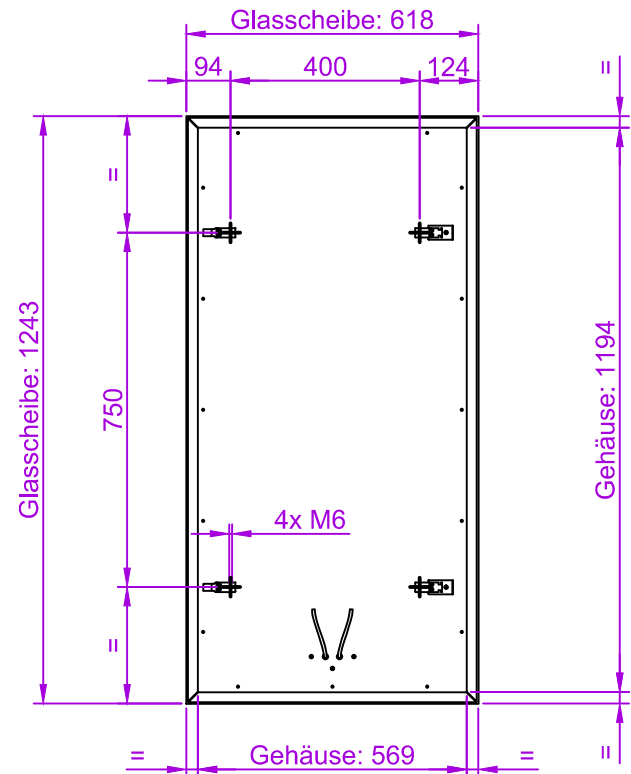

Detail B

Detail C

Seitenansicht

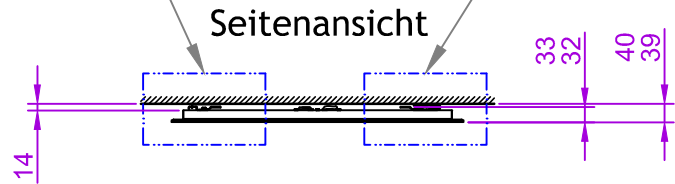

Heizelement aufgeklappt für die Montage des Anschlusskabels

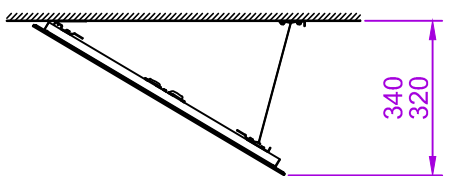

Detail A
(Maßstab 1:1)

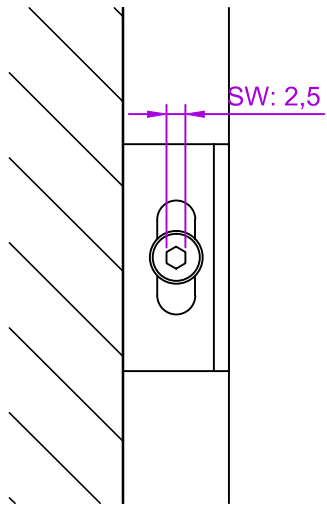

Detail B (Maßstab 1:1)

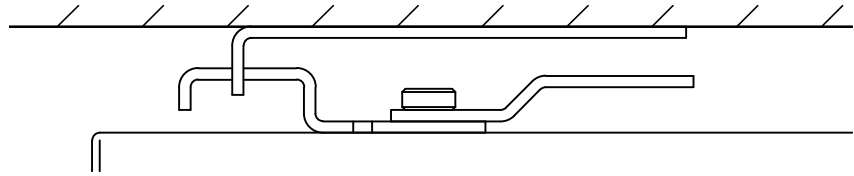

Detail C (Maßstab 1:1)

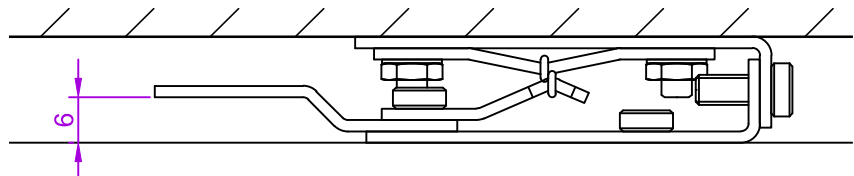

Item	Quantity	Title/Name, material, dimension		Article No./Reference	
Designed by: PR	Checked by: -	Date: 14.10.2010	Project: VH1800	Unit: mm	Scale: 1:16 A4
Vitramo <small>Am Bild 58 D-97941 Tauberbischofsheim info@vitramo.com</small>		 <small>Copyright 2010 Alle Rechte vorbehalten</small>		Title: Montage Number: 2010-111 Version: A Sheet: 1/1	